

TUBO Series

INLINE TYPE DOMESTIC FAN



FEATURES

- Duct mounting
- Easy maintenance
- Low-noise impeller
- Continuous operation
- Ball bearing motor
- 5 Year warranty



Air flow:
up to 295 m³/h
82 l/s



Power:
from 16 W
SFP:
from 0.35 W/l/s



Noise level:
from 38 dB(A)

TECHNICAL DATA

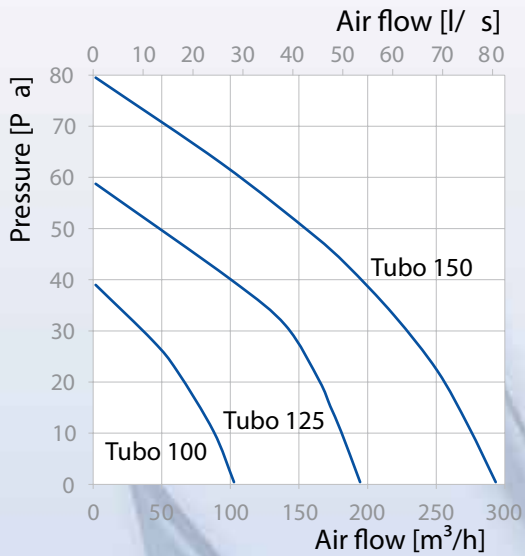

Model	Tubo 100	Tubo 125	Tubo 150
Voltage [V/Hz]	220-240/50	220-240/50	220-240/50
Power [W]	16	22	29
Current [A]	0.085	0.1	0.13
RPM [min ⁻¹]	2300	2400	2400
Air flow [m ³ /h (l/s)]	102 (28)	195 (54)	295 (82)
SFP [W/l/s]	0.56	0.41	0.35
Noise level [dB(A)]	38	39	40

DIMENSIONS

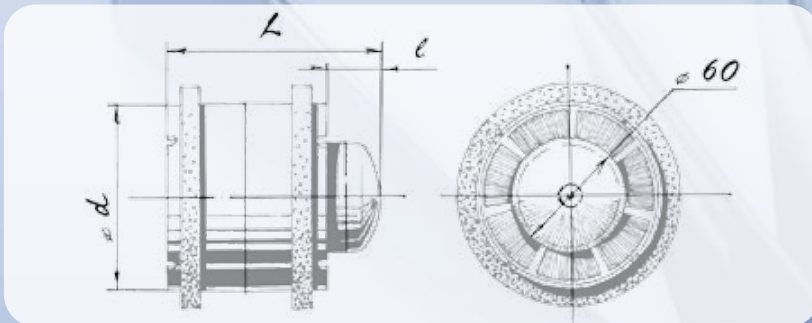

Dimensions [mm]	d	L	l
Tubo 100	98	115	30
Tubo 125	123	115	30
Tubo 150	148	135	30

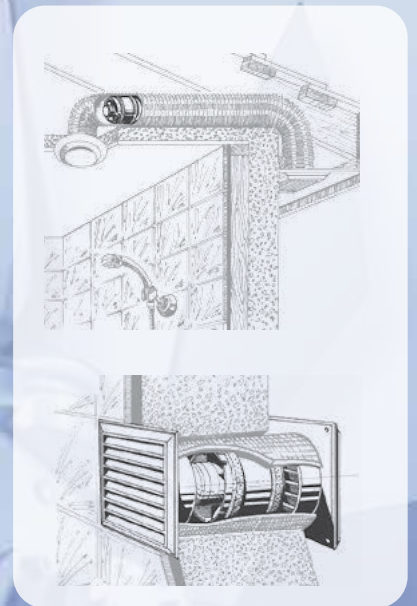

CERTIFICATES



The fans meet the applicable safety and electromagnetic compatibility standards.

ACCESSORIES

